

CD PLAYER

**DP-6020**

---

**INSTRUCTION MANUAL**

KENWOOD CORPORATION

**KENWOOD**



# Introduction

Your choice of this product indicates that you are a devotee of excellence in sound reproduction.

We appreciate your patronage and take pride in the long tradition of quality components that our company represents.

So that you can get the most out of your unit, we suggest that you take the time to read through this manual before you hook up and operate your system. This will acquaint you with the operating features and system-connection considerations, so that your listening pleasure will be enhanced right from the start. You will notice that in all aspects of planning, engineering, styling, operating convenience and adaptability, we have sought to anticipate your needs and desires.

**Keep this manual handy for future reference.**

## For your records

Record the serial number, found on the back of the unit, in the spaces designated on the warranty card, and in the space provided below. Refer to the model and serial numbers whenever you call upon your dealer for information or service on this product.

Model \_\_\_\_\_ Serial Number \_\_\_\_\_

## Unpacking

Unpack the unit carefully and make sure that all accessories are put aside so they will not be lost.

Examine the unit for any possibility of shipping damage. If your unit is damaged or fails to operate, notify your dealer immediately. If your unit was shipped to you directly, notify the shipping company without delay. Only the consignee (the person or company receiving the unit) can file a claim against the carrier for shipping damage.

We recommend that you retain the original carton and packing materials for use should you transport or ship the unit in the future.

for CANADA

### DOC REGULATION

"THIS DIGITAL APPARATUS DOES NOT EXCEED THE CLASS B LIMITS FOR RADIO NOISE EMISSIONS FROM DIGITAL APPARATUS AS SET OUT IN THE RADIO INTERFERENCE REGULATIONS OF THE CANADIAN DEPARTMENT OF COMMUNICATIONS."

**CAUTION:** Use of controls or adjustments or performance of procedures other than those specified herein may result in hazardous radiation exposure.

In compliance with Federal Regulations, following are reproductions of labels on, or inside the product relating to laser product safety.

KENWOOD CORPORATION  
SHIONOGI SHIBUYA BUILDING 17-5, 2-CHOME,  
SHIBUYA, SHIBUYA-KU, TOKYO, JAPAN

KENWOOD CORP. CERTIFIES THIS EQUIPMENT  
CONFORMS TO DHHS REGULATIONS NO. 21 CFR  
1040, 10, CHAPTER I, SUBCHAPTER J.

Location: Back Panel

**DANGER**  
INVISIBLE LASER RADIATION WHEN OPEN  
AND INTERLOCK FAILED OR DEFEATED.  
AVOID DIRECT EXPOSURE TO BEAM.

Location: Inside, near the Laser mechanism.

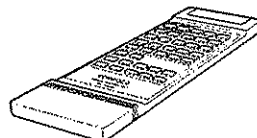
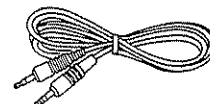
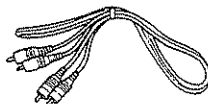

## Accessories

- Audio cord ..... 1
- System control cord . 1  
(Except for the U.K.  
and Europe)
- Remote control unit .. 1
- Battery ..... 2  
("AA" or "R6")



## Contents

**Caution: Read the following pages marked in  carefully to keep your safety.**

 Before applying power .....	3	Manual play (Track mode) .....	12
 Safety precautions .....	3	Programmed play (Program mode) .....	14
 IMPORTANT SAFEGUARDS .....	4	Editing .....	16
Before operation .....	6	Repeated play .....	18
Controls and indicators .....	7	Random play .....	19
System connections .....	8	Time display switching and timer play .....	20
Remote control operation .....	10	In case of difficulty .....	21
Preparing to play .....	11	Specifications .....	22

# Before applying power

## For the U.S.A. and Canada

### Important!

Units shipped to the U.S.A. and Canada are designed for operation on 120 volts AC only.

## For Australia and Europe

### Important!

Units shipped to Australia are designed for operation on 240 V AC only.

Units shipped to Europe are designed for operation on 220 V AC only.

## For the United Kingdom

### Important!

Units shipped to the U.K. are designed for operation on 240 volts AC only.

The mains plug must be removed from the wall socket prior to any internal examination.

The wires in this mains lead are coloured in accordance with the following code:

Blue ..... Neutral  
Brown ..... Live

The wires in this mains lead must be connected to the terminals in the plug as follows:

Wire colour	Plug terminal marking
Blue .....	N or Black
Brown .....	L or Red

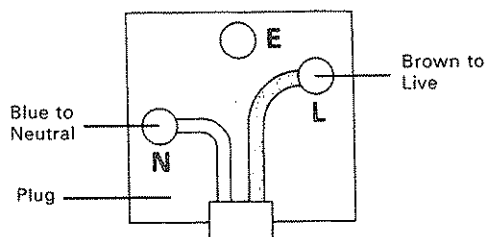

#### Notes:

1. If a 13-amp plug is used, this must be fitted with a 5-amp fuse.
2. If a 3-pin plug with earthing contact is used, no wire must be connected to the E terminal.

## For other countries

### Important!

Units shipped to countries other than the above countries are equipped with an AC voltage selector switch on the rear panel. Refer to the following paragraph for the proper setting of this switch.

### AC voltage selection

This unit operates on 110-120 or 220-240 volts AC. The AC voltage selector switch on the rear panel is set to the voltage that prevails in the area to which the unit is shipped. Before connecting the power cord to your AC outlet, make sure that the setting position of this switch matches your line voltage. If not, it must be set to your voltage in accordance with the following direction.

#### Note:

Our warranty does not cover damage caused by excessive line voltage due to improper setting of the AC voltage selector switch.

AC 110-120V ~ ◀▶ AC 220-240V ~ AC 110-120V ~ ◀▶ AC 220-240V ~

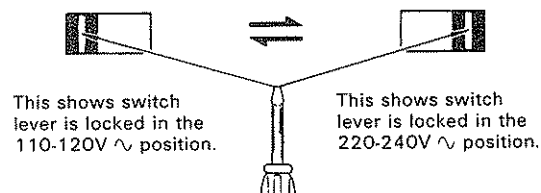

This shows switch lever is locked in the 110-120V ~ position.

This shows switch lever is locked in the 220-240V ~ position.

Move switch lever to match your line voltage with a small screwdriver or other pointed tool.

### AC voltage selector switch

## Safety precautions

**WARNING: TO PREVENT FIRE OR SHOCK HAZARD, DO NOT EXPOSE THIS APPLIANCE TO RAIN OR MOISTURE.**



**CAUTION**  
RISK OF ELECTRIC SHOCK  
DO NOT OPEN



CAUTION: TO REDUCE THE RISK OF ELECTRIC SHOCK, DO NOT REMOVE COVER (OR BACK). NO USER-SERVICEABLE PARTS INSIDE. REFER SERVICING TO QUALIFIED SERVICE PERSONNEL.



THE LIGHTNING FLASH WITH ARROWHEAD SYMBOL, WITHIN AN EQUILATERAL TRIANGLE, IS INTENDED TO ALERT THE USER TO THE PRESENCE OF UNINSULATED "DANGEROUS VOLTAGE" WITHIN THE PRODUCT'S ENCLOSURE THAT MAY BE OF SUFFICIENT MAGNITUDE TO CONSTITUTE A RISK OF ELECTRIC SHOCK TO PERSONS.



THE EXCLAMATION POINT WITHIN AN EQUILATERAL TRIANGLE IS INTENDED TO ALERT THE USER TO THE PRESENCE OF IMPORTANT OPERATING AND MAINTENANCE (SERVICING) INSTRUCTIONS IN THE LITERATURE ACCOMPANYING THE APPLIANCE.

# IMPORTANT SAFEGUARDS

Please read all of the safety and operating instructions before operating this unit. For best results, follow all warnings placed on the unit and adhere to the operating and use instructions. These safety and operating instructions should be retained for future reference.

- 1. Power sources** – The unit should be connected to a power supply only of the type described in the operating instructions or as marked on the appliance.
- 2. Power-cord protection** – Power-supply cords should be routed so that they are not likely to be walked on or pinched by items placed upon or against them, pay particular attention to cords at plugs, convenience receptacles, and the point where they exit from the unit.

Never pull or stretch the cord.

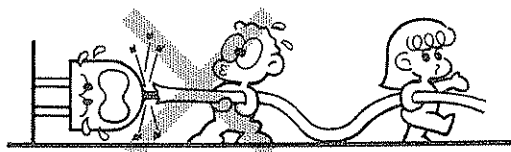

- 3. Grounding or polarization** – The precautions should be taken so that the grounding or polarization means of this unit is not defeated.

- 4. Ventilation** – The unit should be situated so that its location or position does not interfere with its proper ventilation.

To maintain good ventilation, do not put records or a table-cloth on the unit. Place the unit at least 10 cm away from the walls.

Do not use the unit on a bed, sofa, rug or similar surface that may block the ventilation openings.

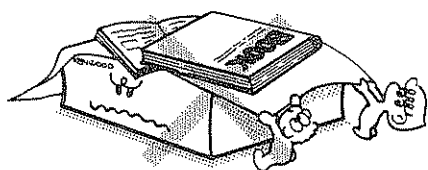

- 5. Water and moisture** – The unit should not be used near water - for example, near a bathtub, washbowl, kitchen sink, laundry tub, in a wet basement, or near a swimming pool, etc.

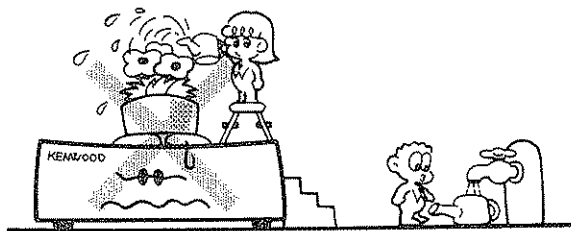

- 6. Temperature** – The unit may not function properly if used at extremely low, or freezing temperatures. The ideal ambient temperature is above +5°C (41°F).

- 7. Heat** – The unit should be situated away from heat sources such as radiators, heat registers, stoves, or other units (including amplifiers) that produce heat.

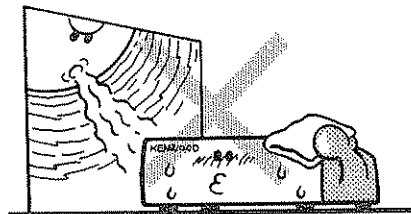

- 8. Electric shock** – Care should be taken so that object do not fall and liquid is not spilled into the enclosure through openings. If a metal object, such as a hair pin or a needle, comes into contact with the inside of this unit, a dangerous electric shock may result. For families with children, never permit children to put anything, especially metal, inside this unit.

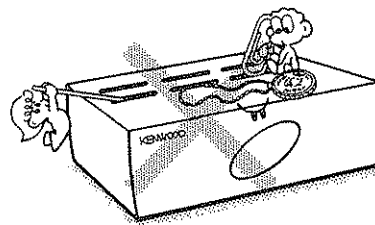

- 9. Enclosure removal** – Never remove the enclosure. If the internal parts are touched accidentally, a serious electric shock might occur.

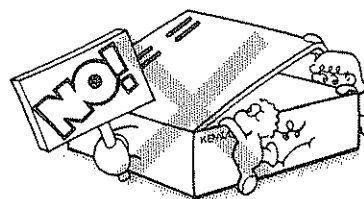

- 10. Magnetic fields** – Keep the unit away from sources of magnetic fields such as TV sets, speaker systems, radios, motorized toys or magnetized objects.

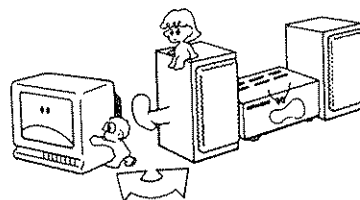

- 11. Cleaning** – Do not use volatile solvents such as alcohol, paint thinner, gasoline, or benzine, etc. to clean the cabinet. Use a clean dry cloth.



**12. Carts and stands** – An appliance and cart combination should be moved with care. Quick stops, excessive force, and uneven surfaces may cause the appliance and cart combination to overturn.



**13. Nonuse periods** – The power cord of the unit should be unplugged from the outlet when left unused for a long period of time.

**14. Abnormal smell** – If an abnormal smell or smoke is detected, immediately turn the power OFF and pull out the power cord. Contact your dealer or nearest service center.

**POWER OFF!**

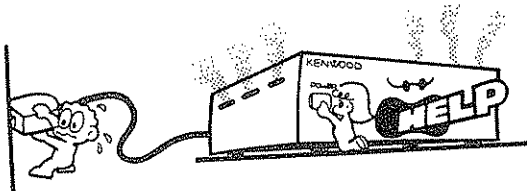

**15. Damage requiring service** – The unit should be serviced by qualified service personnel when:

- A. The power-supply cord or the plug has been damaged; or
- B. Objects have fallen, or liquid has been spilled into the unit; or
- C. The unit has been exposed to rain; or
- D. The unit does not appear to operate normally or exhibits a marked change in performance; or
- E. The unit has been dropped, or the enclosure damaged.

**16. Servicing** – The user should not attempt to service the unit beyond that described in the operating instructions. All other servicing should be referred to qualified service personnel.

**17. Outdoor antenna grounding** – If an outside antenna is connected to the receiver, be sure the antenna system is grounded so as to provide some protection against voltage surges and built up static charges. Section 810 of the National Electrical Code, ANSI/NFPA No. 70 – 1984, provides information with respect to proper grounding of the mast and supporting structure, grounding of the lead-in wire to an antenna discharge unit, size of grounding conductors, location of antenna-discharge unit, connection to grounding electrodes, and requirements for the grounding electrode. See Figure.

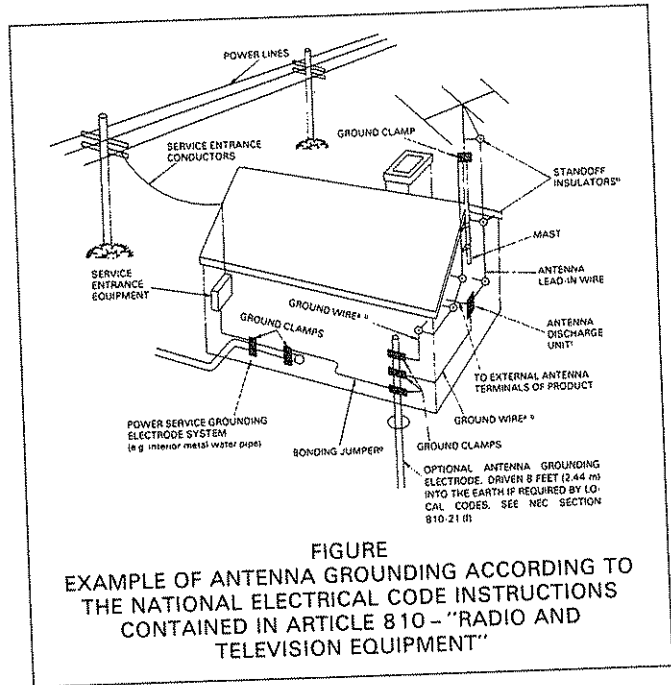

**FIGURE**  
**EXAMPLE OF ANTENNA GROUNDING ACCORDING TO**  
**THE NATIONAL ELECTRICAL CODE INSTRUCTIONS**  
**CONTAINED IN ARTICLE 810 – "RADIO AND**  
**TELEVISION EQUIPMENT"**

- Use No.10 AWG (5.3 mm<sup>2</sup>) copper, No.8 AWG (8.4 mm<sup>2</sup>) aluminum, No.17 AWG (1.0 mm<sup>2</sup>) copper-clad steel or bronze wire, or larger, as a ground wire.
- Secure antenna lead-in and ground wires to house with stand-off insulators spaced from 4 – 6 feet (1.22 – 1.83 m) apart.
- Mount antenna discharge unit as close as possible to where lead-in enters house.
- Use jumper wire not smaller than No.6 AWG (13.3 mm<sup>2</sup>) copper, or the equivalent, when a separate antenna-grounding electrode is used. See NEC Section 810-21(j).

**18. Power lines** – An outdoor antenna should be located away from power lines.

**Notes:**

1. Item 3 is not required except for grounded or polarized equipment.
2. Item 17 and 18 are not required except for units provided with antenna terminals.
3. Item 17 complies with UL-1270 in the U.S.A.

# Before operation

## Precautions concerning CD play

### ■ Disc handling precautions

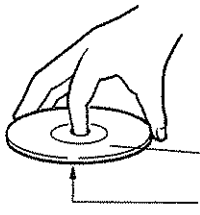

Hold compact discs so that you do not touch the playing surface.

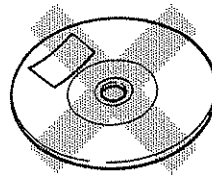

Do not attach paper or tape to either the playing side or the label side of compact discs.

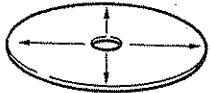

If fingerprints or foreign matter become attached to the disc, lightly wipe the disc with a soft cotton cloth (or similar) from the center of the disc outwards in a radial manner.

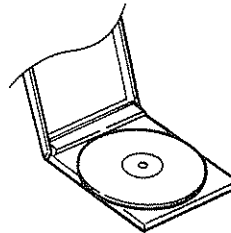
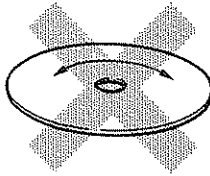

When a disc is not to be played for a long period of time, remove it from the CD player and store it in its case.

### ■ Note related to transportation and movement

Carry out the operations listed below before transporting or moving this unit.

1. After making sure that there is no compact disc loaded in the unit, turn the POWER switch ON.
2. Wait for several seconds to verify that the DISC OUT indicator (OUT) lights on the display, and then turn the POWER switch back OFF.

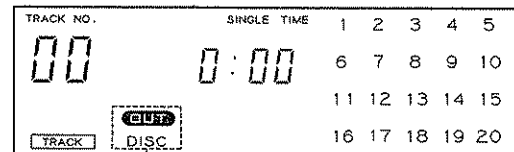

### ■ Beware of condensation

When water vapor comes into contact with the surface of cold material, water drops are produced.

If condensation occurs, correct operation may not be possible, or the unit may not function correctly.

This is not a malfunction, however, and the unit should be dried. (To do this, turn the POWER switch ON and leave the unit as it is for several hours.)

Be especially careful in the following conditions:

- When the unit is brought from a cold place to a warm place, and there is a large temperature difference.
- When a heater starts operating.
- When the unit is brought from an air-conditioned place to a place of high temperature with high humidity.
- When there is a large difference between the internal temperature of the unit and the ambient temperature, or in conditions where condensation occurs easily.

# Controls and indicators

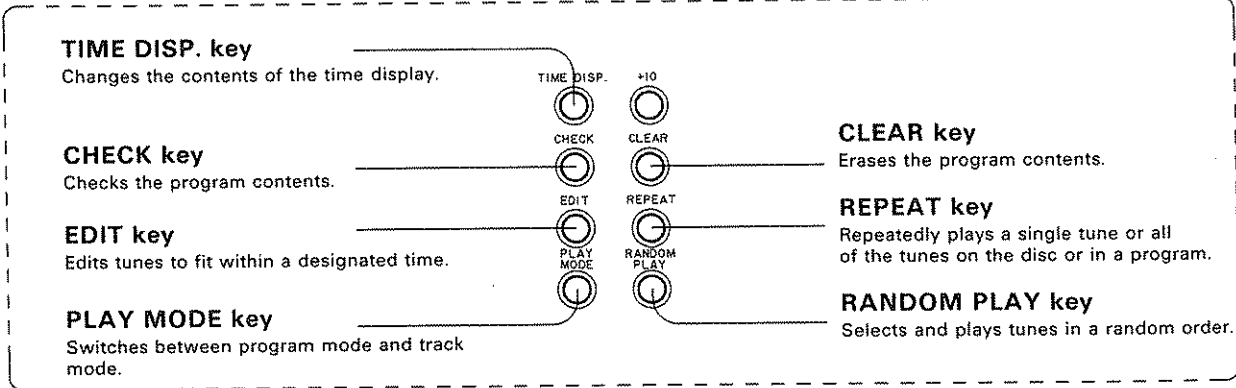
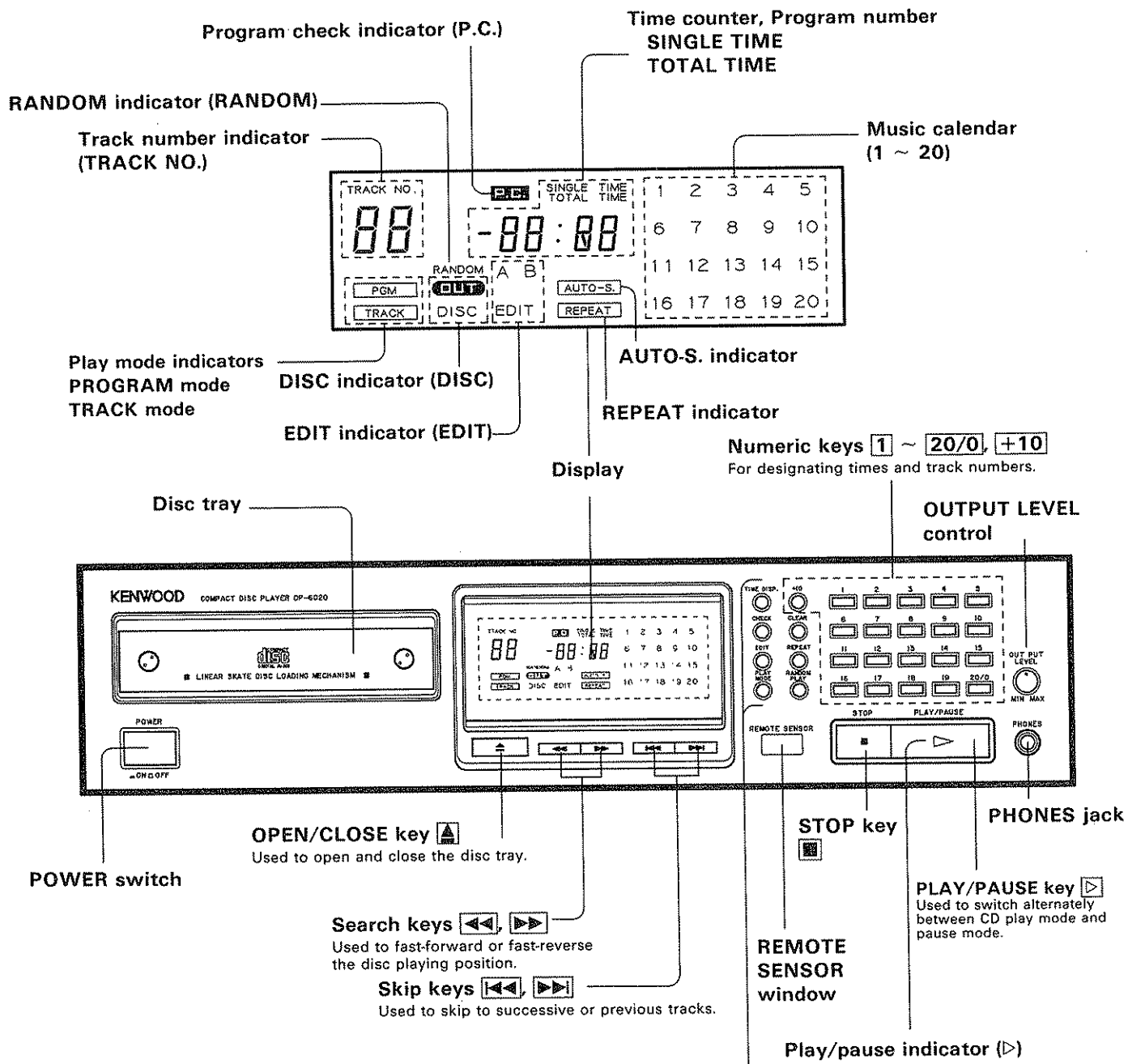

# System connections

Do not plug the AC power cord into the outlet until all connections are completed. Connect the output jacks of this unit to the input jacks of the amplifier using either audio cords or an optical fiber cable. Refer to the instruction manual provided with your amplifier to ensure proper connection.

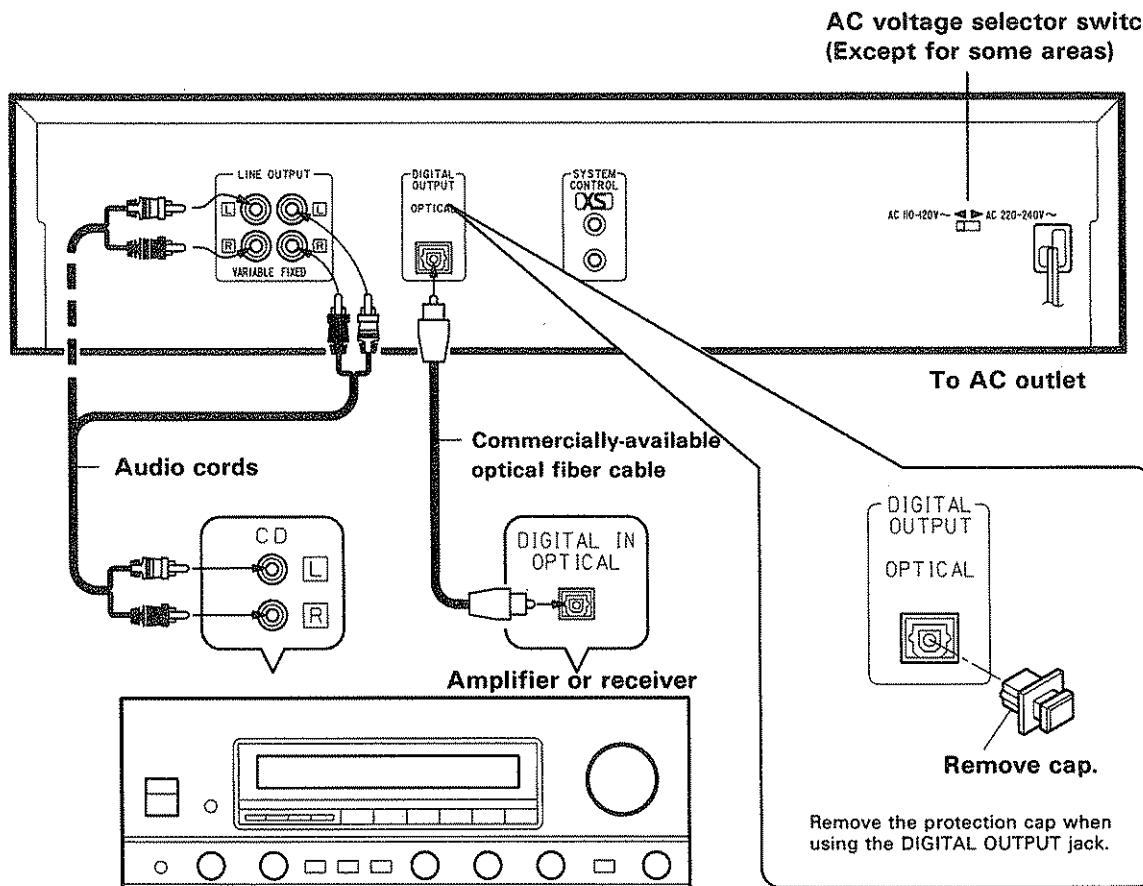

## ■ Connection to a general-use amplifier

Use the provided audio cords to connect the LINE OUTPUT jacks of this unit to the CD input jacks (or AUX jacks) of the amplifier.

- **FIXED** output jacks  
The output level of these jacks remains fixed.
- **VARIABLE** output jacks  
When the OUTPUT LEVEL control on this unit's front panel or the remote control unit is adjusted, the output level of these jacks is varied simultaneously with the output level of the PHONES jack.  
Use these jacks when it is desired to match the output level of this unit with that of another component.

## ■ Connection to a digital amplifier

Use a commercially-available optical fiber cable to connect the OPTICAL DIGITAL OUTPUT jack of this unit to the OPTICAL input jack of the amplifier.

- **OPTICAL DIGITAL OUTPUT** jack  
Digital audio signals are optically converted and output from this jack.  
Use this jack when connecting the player to a digital amplifier provided with an optical input jack.

## Notes:

1. Be sure to connect the connection cord(s) securely. If connections are not made securely, sound may not be produced and/or noise may be generated. Improper connections can also cause player misoperation.
2. Before plugging/unplugging connection cords, be sure to switch the power off and set the amplifier's volume control to its minimum position.  
If connection cords are plugged or unplugged without carrying out the above precautions, malfunction may result.



## System control connections

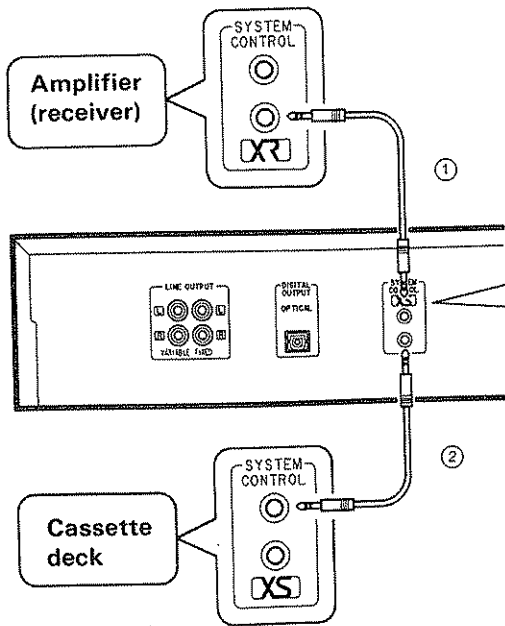

Fully insert the system control plug.

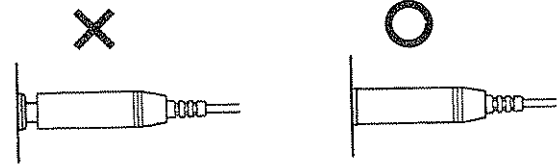

### SYSTEM CONTROL jacks

A variety of system operations are possible when these jacks are connected to the SYSTEM CONTROL jacks of a KENWOOD amplifier and/or cassette deck. Do not connect these jacks to any component other than those specified by KENWOOD, or malfunction may result.

### Note:

When using the System control function, be sure to connect the LINE OUTPUT jacks of this unit to the input jacks of the amplifier using audio cords.

### CCRS

The CCRS function is used when recording from a compact disc to a tape in a cassette deck, and operates to adjust the cassette deck's recording level to the optimum setting according to the playing level of the compact disc. For details on the CCRS function, refer to the instruction manual provided with your cassette deck.

### System operation

#### ① Connection with an amplifier

The SYSTEM CONTROL jacks on KENWOOD amplifiers are marked with either "XR" or "XS". By connecting the SYSTEM CONTROL jack of this unit with that of a KENWOOD amplifier, the following system operations are possible.

When connected to an "XR" jack: The CD player can be controlled as part of the entire system with the remote control unit provided with the amplifier.

When connected to an "XS" jack: The CD player can be controlled as part of the entire system with the remote control unit provided with the amplifier. Also automatic operation is possible.

For details, refer to the instruction manual provided with your amplifier.

#### ② Connection with a cassette deck

By connecting the SYSTEM CONTROL jack of this unit with the "XS" SYSTEM CONTROL jack of a KENWOOD cassette deck, CCRS recording can be carried out.

### Optical fiber cable connection

- When using an optical fiber cable to connect this unit to a digital amplifier, insert the plug straight into the jack until a snap sound is heard.
- Be careful not to bend, coil, or bundle the optical fiber cable.

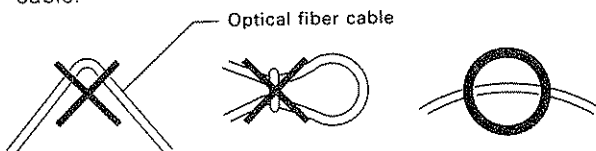

- Optical fiber cables available on the market may not always be able to be used with this player. If your cord cannot be used with this unit, consult the store from which you purchased the cord or your nearest dealer.

OUT PUT  
LEVEL  
MIN MAX

PHONES

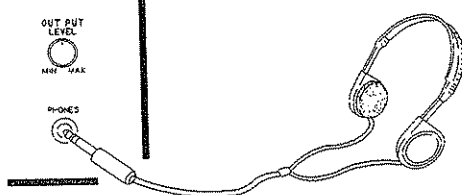

### Using headphones

Insert the plug of a commercially-available pair of headphones into the PHONES jack. Adjust the OUTPUT LEVEL control to set the desired listening level.

# Remote control operation

Most keys have the same functions as the front panel controls.

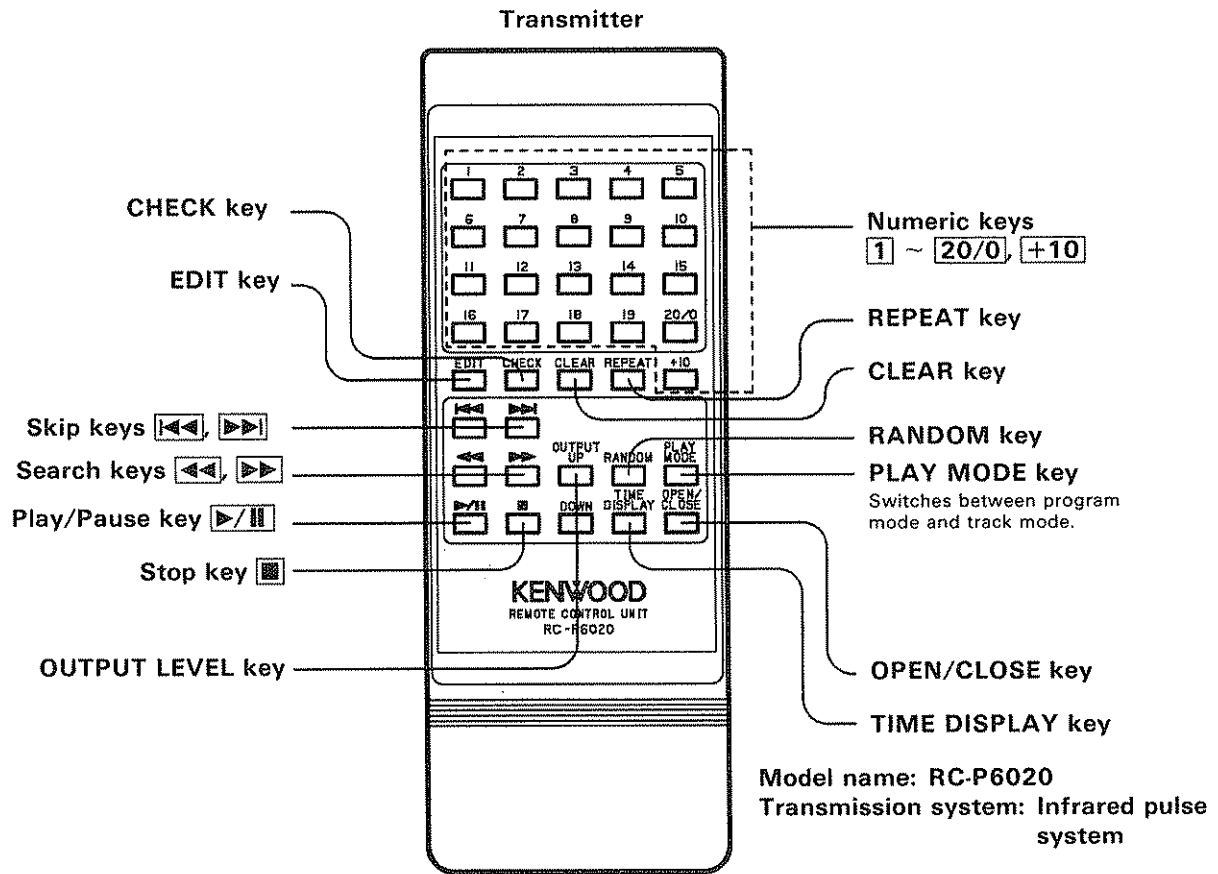

## Remote control operation range

The operation range of the remote control unit varies according to conditions such as temperature, humidity, and use location, but is roughly as shown in the illustration below.

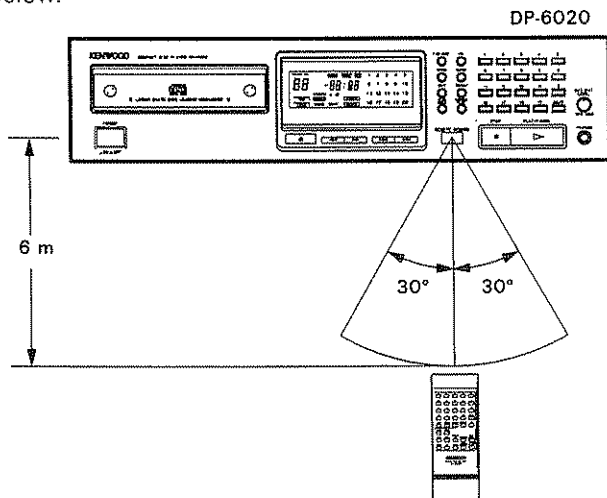

**Note:** Wait at least one second after pressing an operation key on the remote control unit before pressing another key. If you press two keys on the remote control unit quickly in succession, the CD player may not operate correctly.

## Loading batteries

Load two "R6", "AA" size dry batteries into the remote control unit as shown in the illustrations below.

1. Remove the cover.

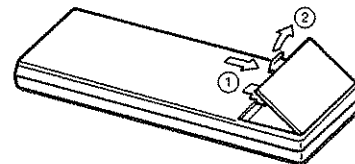

2. Insert the batteries with the correct polarity.

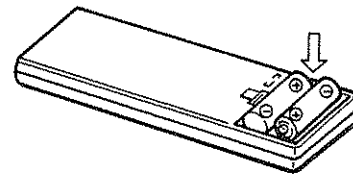

3. Replace the cover.

**Note:** The batteries provided with this unit are for use in checking the operation of the remote control unit and may have a short service life.

When the effective operating distance of the remote control unit becomes noticeably shorter, or if the remote control unit stops operating, replace both batteries with new batteries.

# Preparing to play

When the power is turned on

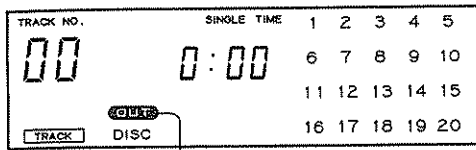

Lights when no disc is loaded.

## Disc types which can be played with this unit

Disc type	Disc size
CD (general compact disc)	12 cm
CD single	8 cm
* CDV (CD with video) – audio part only	12 cm

\* When playing CDVs, the time display shows the total playing time of the audio part only.

## Loading a disc

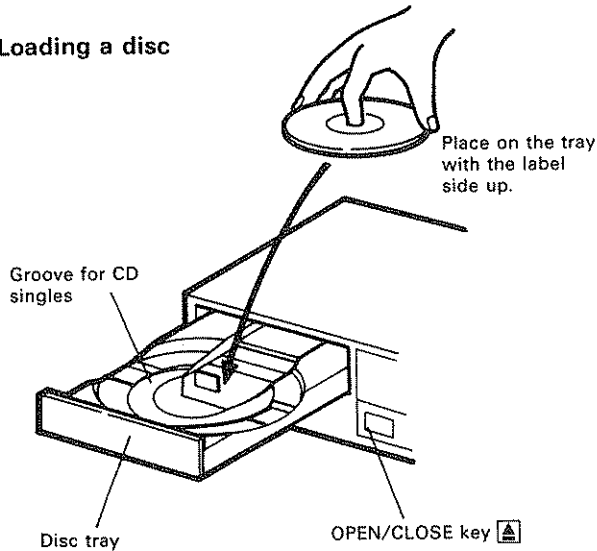

## Loading a disc

1. Press the POWER switch to turn the power on.
2. Press the OPEN/CLOSE key to open the tray.
3. With the label side up, place the disc horizontally in the center of the disc tray.
  - With CD singles (8 cm), be sure to properly place the disc in the center groove of the disc tray.
4. Press the OPEN/CLOSE key to close the tray.

When a disc is loaded and the tray is closed, the display becomes as shown in the illustration below.

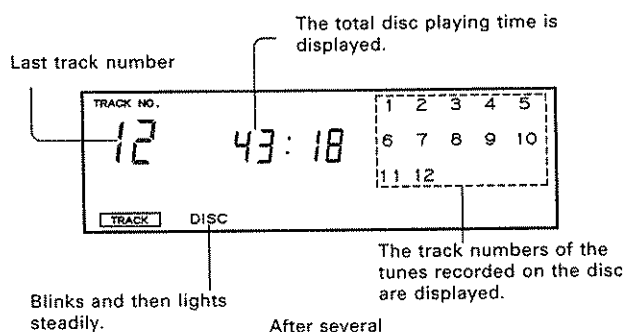

After several seconds...

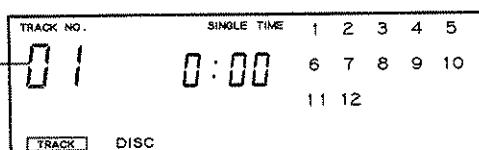

The first track number is displayed.

## Removing a disc

1. Press the OPEN/CLOSE key .
- The tray opens.
2. Remove the disc.
3. Press the OPEN/CLOSE key to close the tray.

## Notes:

1. Be sure that the disc is placed on the disc tray with the label side up. If the disc is loaded upside down, no sound will be produced.
2. Do not place any object other than a disc on the disc tray.
3. A disc may become scratched if it is placed on the tray at an angle.

# Manual play (Track mode)

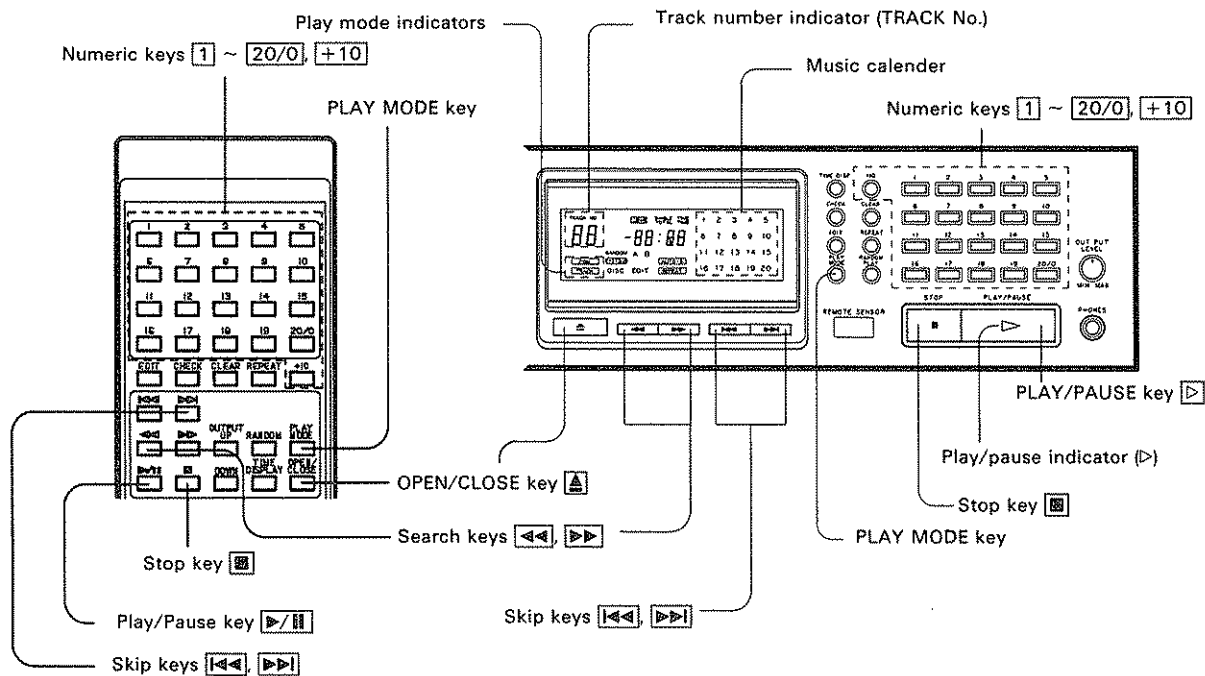

## Set the unit to TRACK mode.

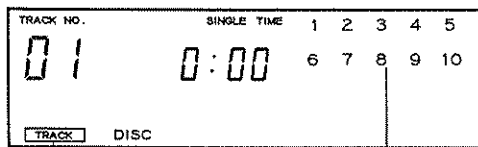

TRACK lights.

The track numbers of the tunes recorded on the disc are displayed.

## When the PLAY/PAUSE key is pressed.

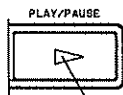

Lights (green).



The elapsed time is displayed.

## Example showing the display when the player is put into pause mode during playback of track number three.



Blinks (amber).

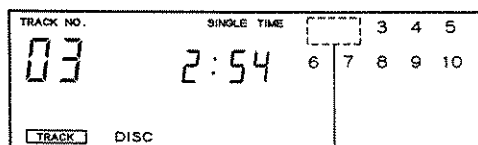

The track numbers of the tunes which have finished playing are extinguished sequentially.

## To play from the first tune

- Ensure that the PLAY MODE indicator shows **TRACK**.
  - If **PGM** is lit, press the PLAY MODE key so that **TRACK** lights up.
- Press the PLAY/PAUSE key.
  - After several seconds, the player begins playing the first tune.
  - If a disc is present in the player when the power is turned on, play begins automatically from the first tune on the disc.

## To temporarily pause disc play

Press the PLAY/PAUSE key.

- The pause indicator (▷: amber) blinks and play is paused at the current position.
- If the PLAY/PAUSE key is pressed again, play is resumed from the same location.
- If the player is left in pause mode for approximately 30 minutes, pause mode is automatically canceled and the unit enters stop mode.

## To stop play

Press the STOP key.

- The play indicator (▷) goes out and play stops.

### Example: Playing from track number 23.

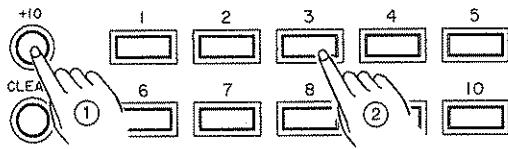

Press the **+10** key twice.  
Press the **3** key once.

### Example: Display when play begins from track number 23.

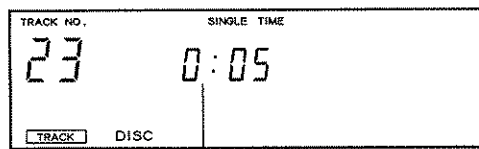

The elapsed time is displayed.

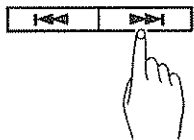

When this key is pressed during stop mode, play begins from the beginning of the second track.

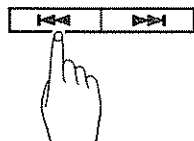

When this key is pressed during stop mode, play begins from the beginning of the last track.

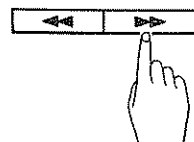

When this key is pressed during disc play, the sound level is reduced while the play position is advanced. Normal play resumes when the key is released.

### ■ To play from a designated tune

1. Verify that the TRACK mode indicator **TRACK** is lit.
  - If **PGM** is lit, press the PLAY MODE key so that **TRACK** lights up.
2. Enter the desired track number using the numeric keys **1** - **20/0** and **+10**.
  - The **20/0** key is used to select track number "20" or to designate the "0" for track number 30, 40, etc.Examples:  
To enter track number 23, press the **+10** key twice and then press the **3** key.  
To enter track number 40, press the **+10** key four times and then press the **20/0** key.
  - The designated track number appears in the track number indicator (TRACK NO.) section of the display and play begins from the designated track.

#### Note:

If a track number which does not exist on the disc is designated while the tray is open, only the last track will be played. Also, if a track number which does not exist on the disc is designated while the disc is being played, the designated track number will not be accepted.

### ■ To skip to a tune located after or before the current tune

While looking at the track number on the display, press the SKIP key **▶▶** (or **◀◀**).

- If the key is pressed once, the next (or previous) tune will be selected. If the key is pressed several times in succession or held pressed, a tune located several places after (or before) the current tune will be selected.
- Play begins from the beginning of the selected tune.
- If the **◀◀** key is pressed once during play, the current tune will be played again from the beginning.
- If one of the SKIP keys is operated during pause mode, play will begin from the selected tune when the PLAY/PAUSE key **▶** is pressed to cancel the pause mode.

### ■ To fast-forward or fast-reverse the playing location

Press the search key **▶▶▶** (or **◀◀◀**).

- If the key is held pressed for more than approximately 2 seconds, the fast-forward (or fast-reverse) speed will be increased.

# Programmed play (Program mode)

Up to 20 tunes can be programmed and played in any desired order.

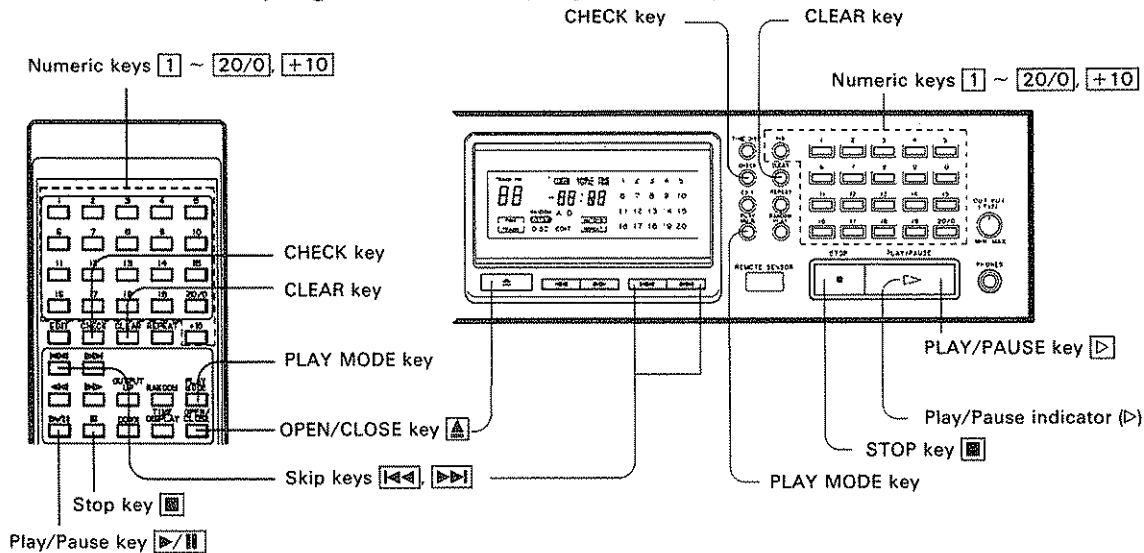

When the play mode is set to program mode.

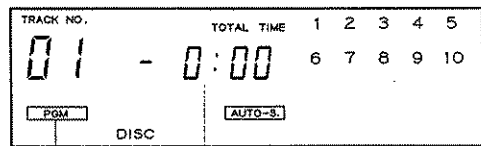

PGM lights. The display changes from SINGLE TIME to TOTAL TIME.

Example showing the display when track number 5 is programmed.

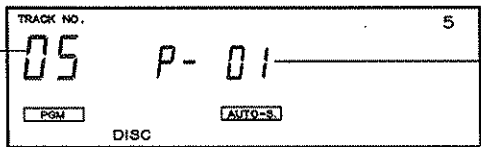

Track number of selected track. Program number



After several seconds...

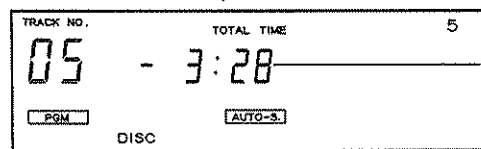

Total playing time

When track number 44 or above is selected.

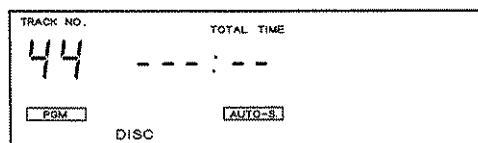

## To program tunes

1. Press the PLAY MODE key to enter the Program mode.
2. Enter the track number of the desired tune using the numeric keys [1] - [20/0] and [+10].  
Example: If the [5] key is pressed the display becomes as shown in the illustration on the left. It is possible to go ahead and program the next track without waiting for the display to change.

- When a track is programmed, the green play/pause indicator (▷) blinks.

- If desired, you can carry out programming with the disc tray open in order to see the disc label.

3. Up to 20 tracks can be programmed in the same manner.

- If you mistakenly enter an incorrect track number, press the CLEAR key once and re-enter the correct track number.

- If a track number which does not exist on the disc is entered when the disc tray is open, the player will go ahead and program that track number. However, when the disc tray is closed, that track number is automatically deleted from the program.

- If track number 44 or above is selected, the track will be programmed but the remaining play time for that track and the total remaining play time for the disc will not be displayed.

## AUTO SPACE function

In program mode, the [AUTO-S.] indicator lights and a 4-second (approx.) blank space is automatically inserted between all of the tunes during play. This is a convenient function which is utilized by the DPSS system found on KENWOOD cassette decks.

- Some compact discs such as the compact disc types listed below are divided into tracks even though there is no actual break between selections. When these

types of compact discs are played, this player may automatically insert a 4-second blank space at the track divisions.

- ① Compact discs such as classical music CDs which contain long selections which are divided into different movements or parts.
- ② Compact discs such as live music CDs where the next tune begins before the applause between the tunes is completely finished.

### Example of display when the CHECK key is pressed.

The program check indicator **P.C.** lights for several seconds and then goes out.

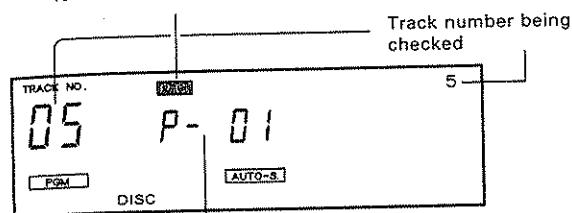

The program number of the program being checked is displayed for several seconds and then the display returns to the total time display.

### Example of display after the program is changed.

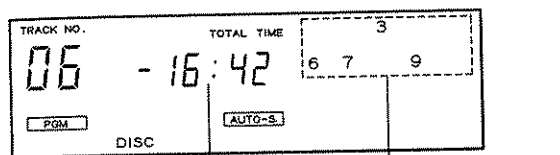

The program number is displayed for several seconds and then the display returns to the total time display.

### To check the program

Press the CHECK key.

- Each time the CHECK key is pressed, the track number of the next tune in the program is displayed.

### To change the program



1. Use the CHECK key to select the program number you wish to change.
2. While the program check indicator (P.C.) is being displayed, use the numeric keys to select the track number of the desired tune.
  - It is not possible to change a tune which is currently being played.

### To play programmed tunes

After programming is completed, press the PLAY/PAUSE key .

- The play/pause indicator () , which was blinking during the programming operation, now lights steadily (green), and play begins in the programmed sequence.

### To begin program play from the desired programmed tune

1. Play is advanced to the next programmed tune each time the forward skip key  is pressed.
2. Play returns to the previous programmed tune each time the backward skip key  is pressed.
  - Play begins from the beginning of the selected tune.
  - If the  key is pressed once during program play, the current tune will be played again from the beginning.

### To stop program play

Press the STOP key .

### To add tunes to the end of a program

When the numeric keys **[1]-[20/0]** and **[+10]** are used to enter desired tunes while the player is in program mode, the tunes are automatically added to the end of the program.

### To erase a program

Press the CLEAR key.

- Each time the CLEAR key is pressed, the last tune in the program is deleted.
- The entire contents of the program will be erased when one of the following operations is carried out.
  - ① When the PLAY MODE key is pressed to switch from program mode to track mode.
  - ② When the disc tray is closed and the OPEN/CLOSE key  is pressed.
  - ③ When the unit is in stop mode and the CLEAR key is pressed the same number of times as the number of programmed tunes.

### Program memory backup function

Even if the power is turned off after a program has been created, the contents of the program will be saved in the unit's backup memory (for approximately two days). When the power is turned back on again, the unit will begin playing the tunes in the programmed order. This function is useful when the CD player is used for timer play with an audio timer.

- The edit, random play, and repeat functions are not backed up.

# Editing

When a CD is recorded onto a cassette tape, the Edit function automatically selects and programs tracks in two groups for tape sides A and B so that the tracks can be recorded within the specified recording time of each side without being interrupted at the ends of tape.

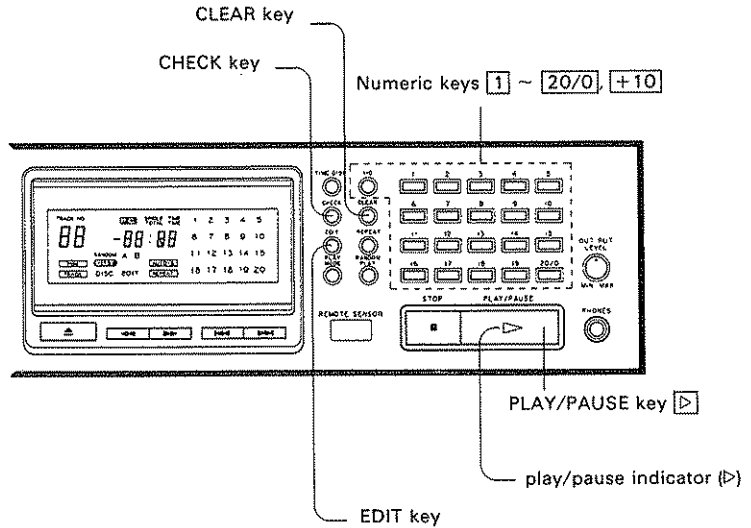
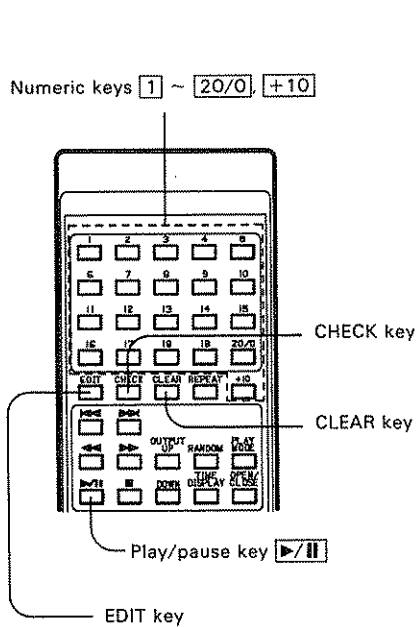

## When the EDIT key is pressed

When the EDIT key is pressed, the player automatically switches to program mode.

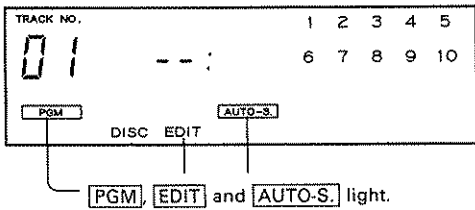

## Display when editing for one side of tape has completed

Remaining tape time is displayed for a few seconds.

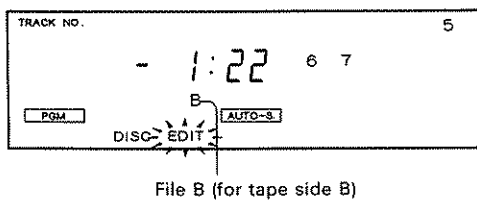
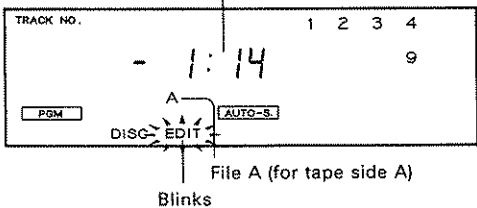

## When editing is finished

Total play time

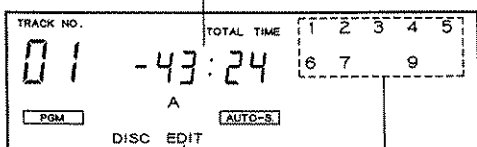

Continuous lighting resumes after editing.

Track Nos. of the tracks edited by program editing

## To edit tracks

1. With the player in stop mode, press the EDIT key.
2. Within 5 seconds after pressing the EDIT key, set the required recording time of both sides using the numeric keys.
  - The recording time can be set in one-minute units (2 digits) up to a maximum time of 99 minutes. Example: To edit tunes to fit within a recording time of 46 minutes Press the [+10] key four times and then press the [6] key.

## The editing is performed as follows.

- ① The set recording time is divided by two (to 23 minutes in the example above), and tracks that can be accommodated in file A (program for tape side A) are selected and arranged in order from the smallest track No. to larger track Nos.
  - If the RANDOM PLAY key had been pressed before the recording time was set with the numeric keys, the tracks are selected in a random order.
- ② In a few seconds, the expected remaining time after file A is displayed. Then the tracks for file B (for tape side B) starts to be edited in the similar method.
  - When the EDIT operation is carried out after a designated tune is programmed, the programmed tune is given priority and then other tunes are added to the program in the order of their track numbers according to the amount of time remaining.



Example of when the CHECK key is pressed.

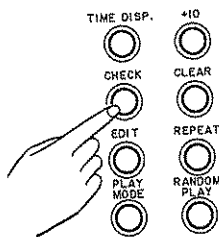

The program check indicator [P.C.] lights for several seconds and then goes out.

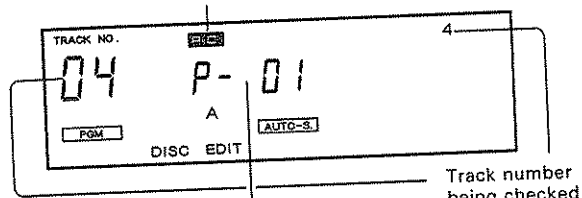

The program number being checked is displayed for several seconds and then the display returns to the total time display.

### Canceling the EDIT function

When the PLAY MODE key is pressed with the player in stop mode

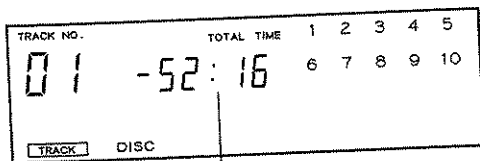
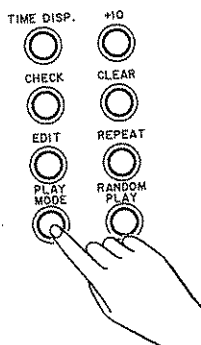

The total play time of the disc is displayed.

### To check the edited program contents Press the CHECK key.

- Each time the CHECK key is pressed, the track numbers of the edited tunes are displayed in sequence starting from the beginning of the A file and continuing through to the end of the B file.

### To play an edited program Press the PLAY/PAUSE key [▶].

- The tunes in the A file are played in sequence and the player enters pause mode at the beginning of the B file.
- To play the tunes in the B file, press the PLAY-/PAUSE key [▶] again.

### To erase the edited program contents

After editing is completed, the entire contents of the edited program will be erased when one of the following operations is carried out.

- When the PLAY MODE key is pressed to switch the unit to TRACK mode.
- When the player is in stop mode and the CLEAR key is pressed the same number of times as the number of programmed tunes.
- When the OPEN/CLOSE key [⏏] is pressed.

#### Notes:

- If a time is set which differs from the recording time of the tape, the player will edit the tunes according to the set time, which may result in a long non-recorded space being left at the end of each side of the tape or a tune being cut off in the middle at the end of side A and/or side B.
- The EDIT function can edit a maximum of 20 tunes.
- If a tune with a track number of 44 or higher is programmed, the EDIT function will not operate.
- The EDIT function will not operate correctly with compact discs such as classical music CDs which have one or more tracks with long play times.

# Repeated play

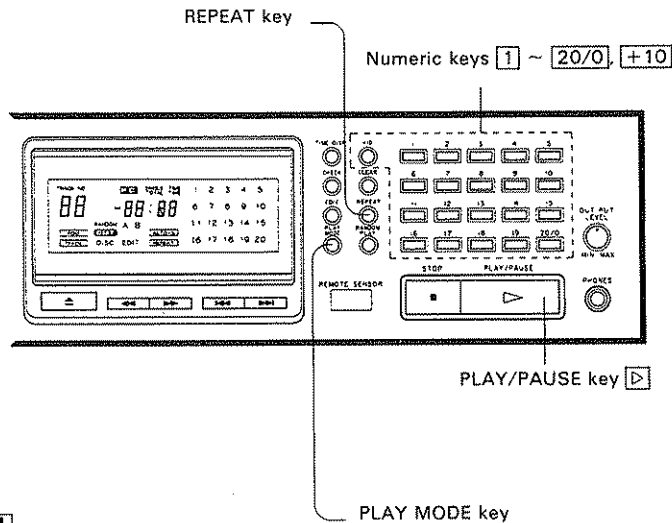
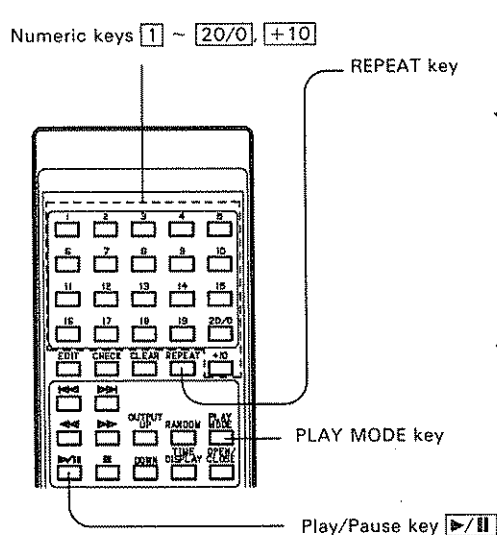

When the REPEAT key is pressed

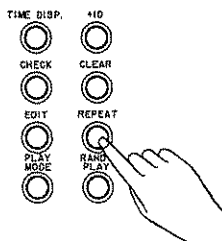

## ■ To repeatedly play all tunes

1. Press the REPEAT key.
2. Press the PLAY/PAUSE key .
  - When the player is in track mode, all of the tracks on the disc are played repeatedly.
  - When the player is in program mode, all of the programmed tracks are played repeatedly.

## ■ To repeatedly play a single tune

1. Press the PLAY MODE key to set the player to program mode.
2. Program the track number of the desired tune.
3. Press the REPEAT key.
4. Press the PLAY/PAUSE key .

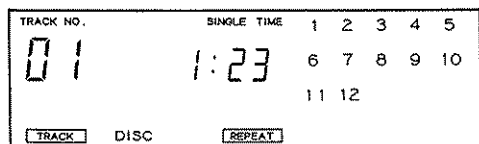

REPEAT lights.

## ■ To cancel repeat play

- Press the REPEAT key again.
- Repeat play can also be canceled by pressing the OPEN/CLOSE key .

# Random play

With the RANDOM function, every time a disc (or program) is played, the tunes are selected and played in random order. If the RANDOM function is used together with the REPEAT function, a disc can be repeatedly played for long periods of time without the listener losing interest.

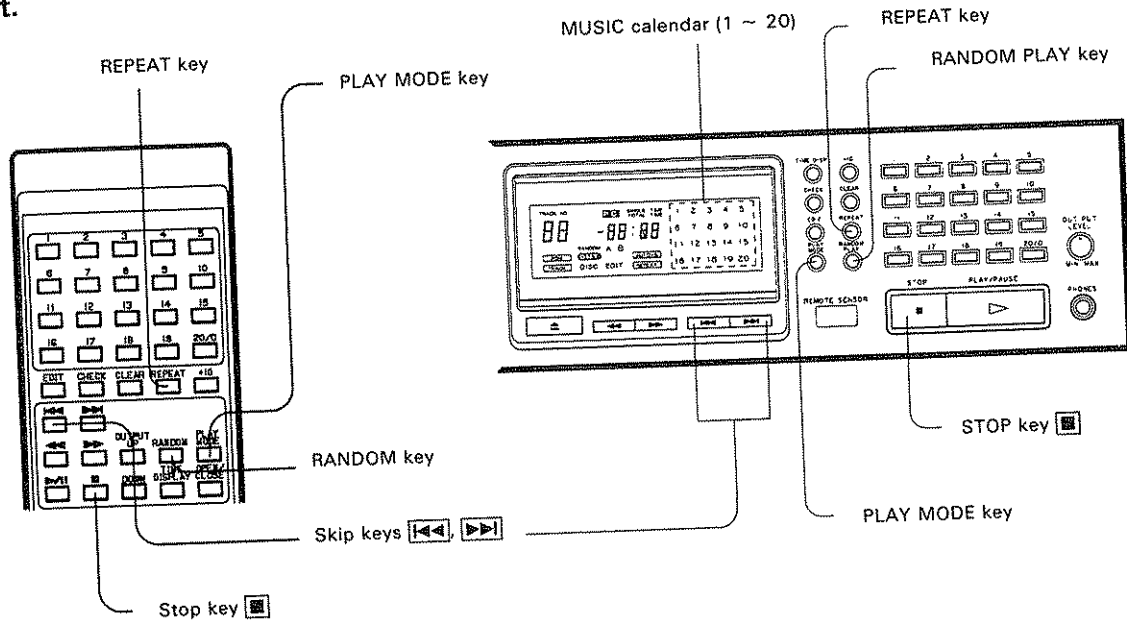

## ■ To carry out random play

Press the RANDOM PLAY key.

- When the player is in track or time mode, a tune with a track number in the range of 1 to 20 is randomly selected and play begins.
- When the player is in program mode, a tune is randomly selected from among the programmed tunes and play begins.
- If the skip key is pressed, another tune is randomly selected and played.
- If the skip key is pressed once, the tune currently being played will be played again from the beginning.
- When the end of one tune is reached, another tune is randomly selected and played.
- Random play stops after all of the tunes have been played once.
- If the REPEAT key is pressed, random play operation is repeated continuously.

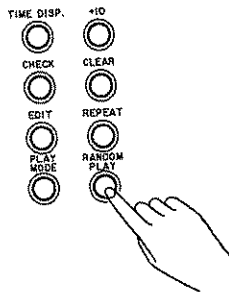

Example of when track number 7 is selected

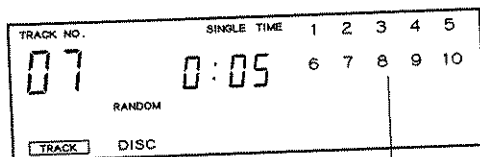

The track numbers of the tunes recorded on the disc are displayed.

Example of when track number 3 is next selected

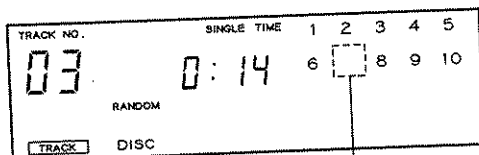

The track number of the tunes which have finished playing are extinguished sequentially.

## ■ To cancel random play

Random play will be canceled when one of the following operations is carried out.

- ① When the RANDOM PLAY key is pressed again.
- ② When the STOP key is pressed.
- ③ When the OPEN/CLOSE key is pressed.
- ④ When a numeric key is pressed.
- ⑤ When the PLAY MODE key is pressed.
- ⑥ When the CLEAR key is pressed during random play operation in program mode.

# Time display switching and timer play

## ■ To change the time display

While a disc is being played in any of the play modes, or when the player is in stop mode, you can change the time display contents by pressing the TIME DISPLAY key on the remote control unit. The contents of the time display change each time the TIME DISPLAY key is pressed, according to the following cycle.

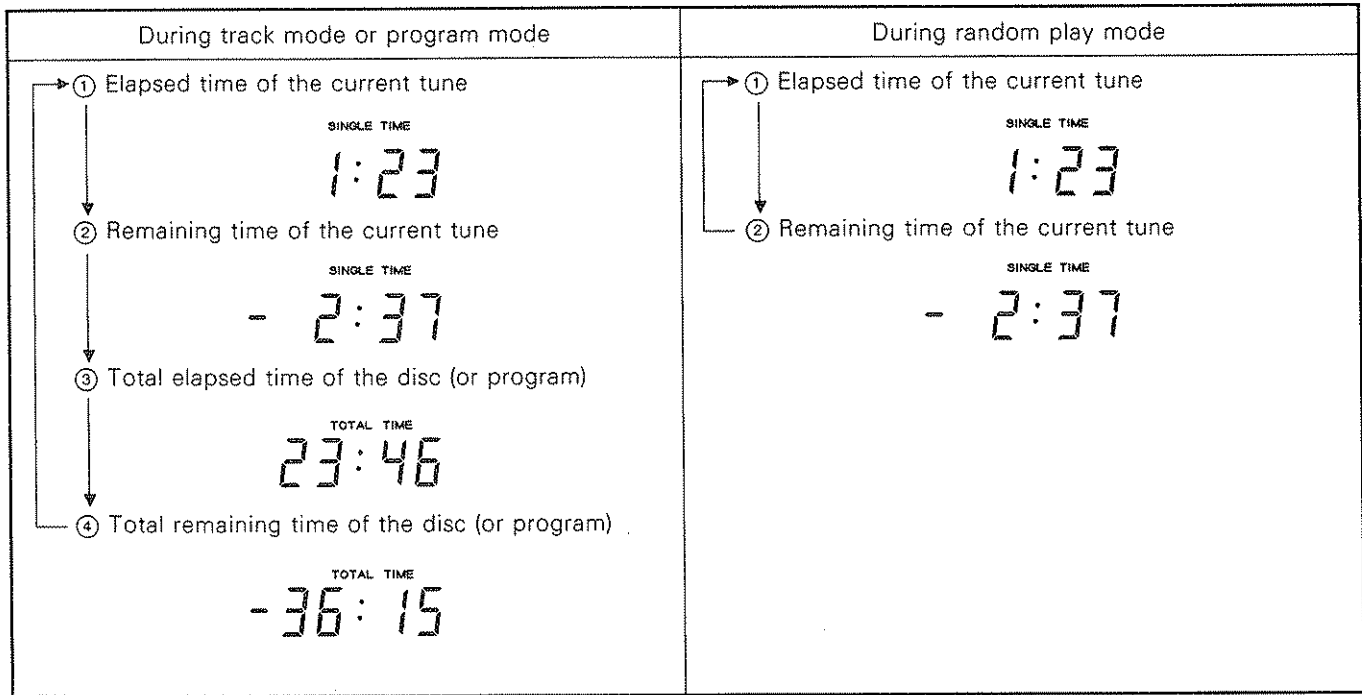

### Note:

With this unit, the time information recorded on the disc for a maximum of 43 tunes can be stored in memory. When playing discs which contain more than 44 tunes, or when the total playing time of a program is 100 minutes or longer, the time may not be shown on the time display.

In this case, the display will show --:--.

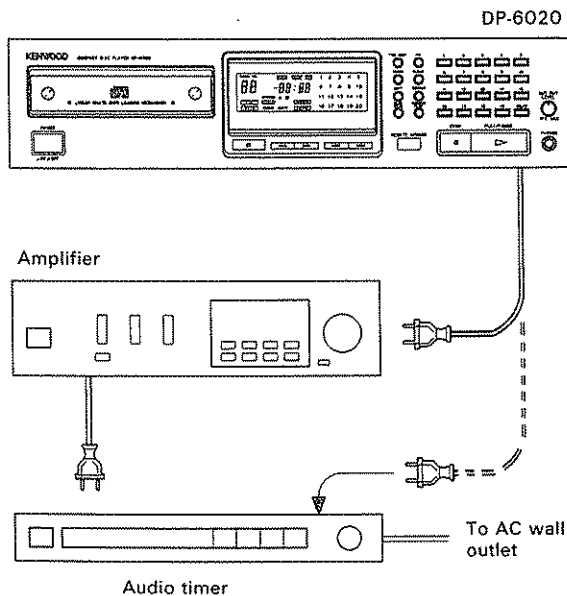

## ■ To carry out timer play

Connect the power cord of this unit to an audio timer, load a disc into the disc tray, set the desired time on the timer, and set the POWER switch on the player to ON.





- When the time set on the timer arrives, the power to the player is turned on and disc play begins automatically.
- By using the program memory backup function, desired tunes can be played in the desired order.
- The memory backup function saves program contents for approximately two days.

### Notes:

1. Refer to the instruction manual provided with the audio timer before making connections and settings.
2. When using an audio timer to automatically begin disc play, be careful that the volume on the amplifier is set to an appropriate level.
3. When using an audio timer to operate a component other than the CD player, be sure to remove the disc from the player's disc tray.

# In case of difficulty

If your player should not perform as expected, consult the table below to see if the problem can be corrected before seeking help from your dealer or service representative.

Symptom	Cause	Remedy
No power is supplied to the player when the POWER switch is ON.	<ol style="list-style-type: none"> <li>1. The power cord plug is not plugged in completely.</li> <li>2. The power cord plug is connected to a switched outlet on the amplifier and the power to the amplifier is not turned on.</li> </ol>	<ol style="list-style-type: none"> <li>1. Insert the power cord plug firmly into the outlet.</li> <li>2. Turn on the power to the amplifier.</li> </ol>
A disc is loaded but cannot be played. The DISC OUT indicator  remains lit and nothing happens when the PLAY/PAUSE key  is pressed.	<ol style="list-style-type: none"> <li>1. The disc is loaded upside down.</li> <li>2. The disc is very dirty.</li> <li>3. The disc is scratched or damaged</li> <li>4. The optical lens is fogged with condensation.</li> </ol>	<ol style="list-style-type: none"> <li>1. Load the disc again, making sure that the label side is up.</li> <li>2. Clean the disc according to the instructions in the "Disc handling precautions" section.</li> <li>3. Replace the disc with a new one.</li> <li>4. Leave the unit for about 1 hour with the power ON so that the condensation evaporates.</li> </ol>
No sound is produced.	<ol style="list-style-type: none"> <li>1. No disc is loaded.</li> <li>2. The unit is not in play mode. (The play indicator  is not lit.)</li> <li>3. The disc is very dirty.</li> <li>4. The disc is scratched or damaged.</li> <li>5. The connection cords are not securely connected.</li> <li>6. The player is connected to the amplifier via the VARIABLE jacks and the OUTPUT LEVEL control is set to "MIN".</li> </ol>	<ol style="list-style-type: none"> <li>1. Load a disc and press the PLAY/PAUSE key .</li> <li>2. Press the PLAY/PAUSE key .</li> <li>3. Clean the disc according to the instructions in the "Disc handling precautions" section.</li> <li>4. Replace the disc with a new one.</li> <li>5. Securely connect the connection cords.</li> <li>6. Adjust the output level using the OUTPUT LEVEL keys on the remote control unit or the OUTPUT LEVEL control on the player.</li> </ol>
The sound skips or is interrupted.	<ol style="list-style-type: none"> <li>1. The disc is very dirty.</li> <li>2. The disc is scratched or damaged.</li> <li>3. The player is subjected to vibrations.</li> </ol>	<ol style="list-style-type: none"> <li>1. Clean the disc according to the instructions in the "Disc handling precautions" section.</li> <li>2. Replace the disc with a new one.</li> <li>3. Install the unit so that it is not subjected to vibrations by moving the player to a different location, etc.</li> </ol>
Play begins as soon as the power is turned on.	This unit is designed so that play begins automatically when the power is turned on if a disc is already loaded.	If automatic play is not required, remove the disc from the player before turning the power OFF.

## Notes:

1. Since this unit incorporates a microprocessor, external noise or interference may cause the unit to operate abnormally. If this should ever occur, press the POWER switch OFF and then press it ON again after a period of several seconds.
2. Contact restoring agents may cause malfunction and therefore should not be used. Contact restoring agents which contain oil should especially be avoided, as they can cause deformation of plastic parts.

# Specifications

---

## [Format]

Type ..... Compact disc player  
Read system ..... Non-contact optical pick-up  
Rotational speed ..... About 200 to 500 rpm

## [Audio]

Frequency response ..... 2 Hz ~ 20 kHz  $\pm$ 0.5 dB  
Signal-to-noise ratio ..... more than 107 dB  
Total harmonic distortion ..... 0.0025% at 1 kHz  
Channel separation ..... more than 102 dB at 1 kHz  
Wow & flutter ..... Below measurable limit

## Output

LINE (FIXED) ..... 2.0 V  
(VARIABLE) ..... 0 - 2.0 V  
DIGITAL (OPTICAL) ..... -15 dBm - -21 dBm  
Headphone jack ..... 20 mW (8  $\Omega$ )

## [General]

Power consumption ..... 13W  
Dimensions ..... W: 440 mm  
H: 117 mm  
D: 314 mm  
Weight ..... 4.5 kg

---

## Note:

KENWOOD follow a policy of continuous advancements in development. For this reason specifications may be changed without notice.

---

KENWOOD